

Wilo-Helix V, FIRST V, 2.0-VE 2-4-6-10-16



en Installation and operating instructions



Fig. 1

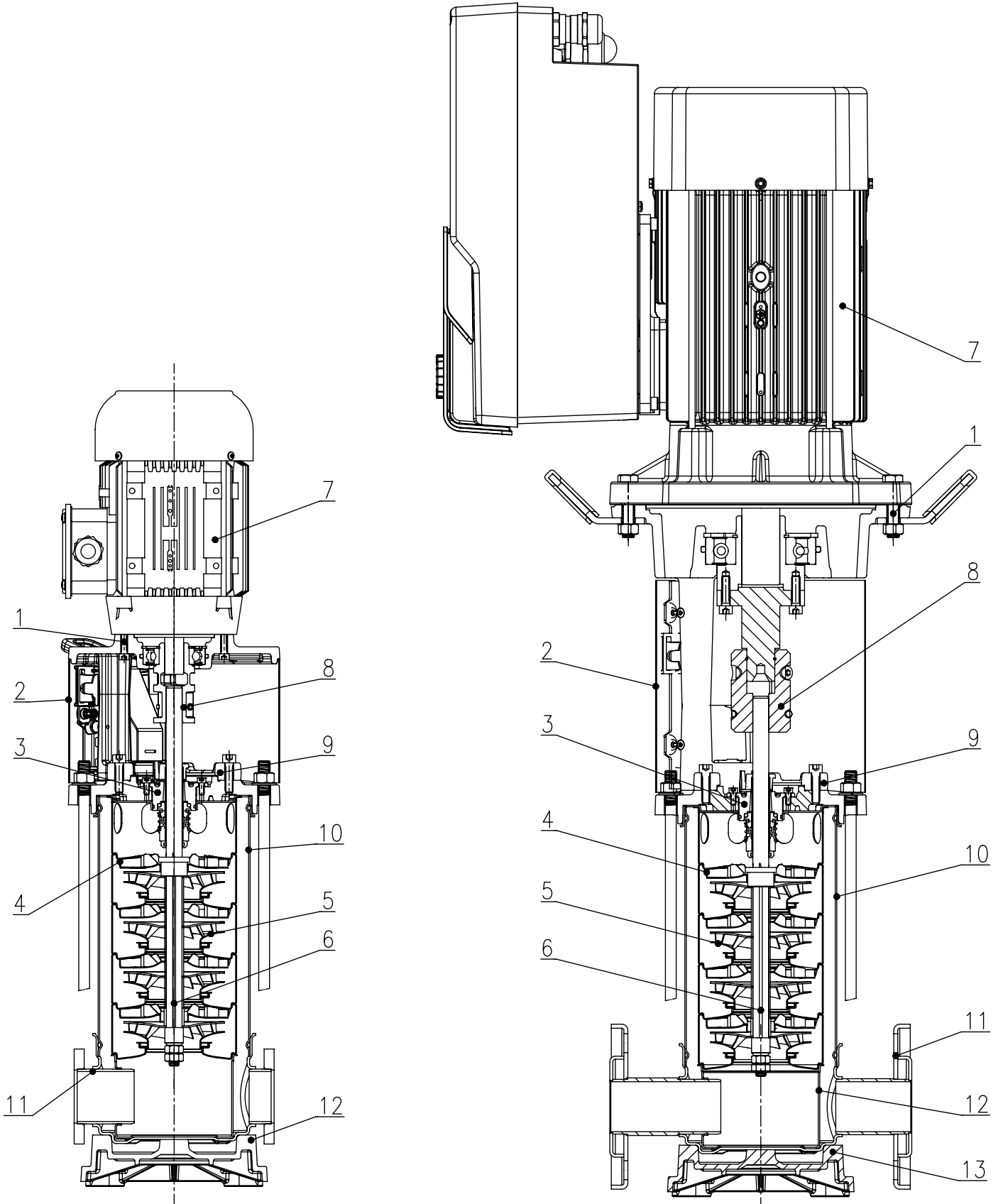

Fig. 2

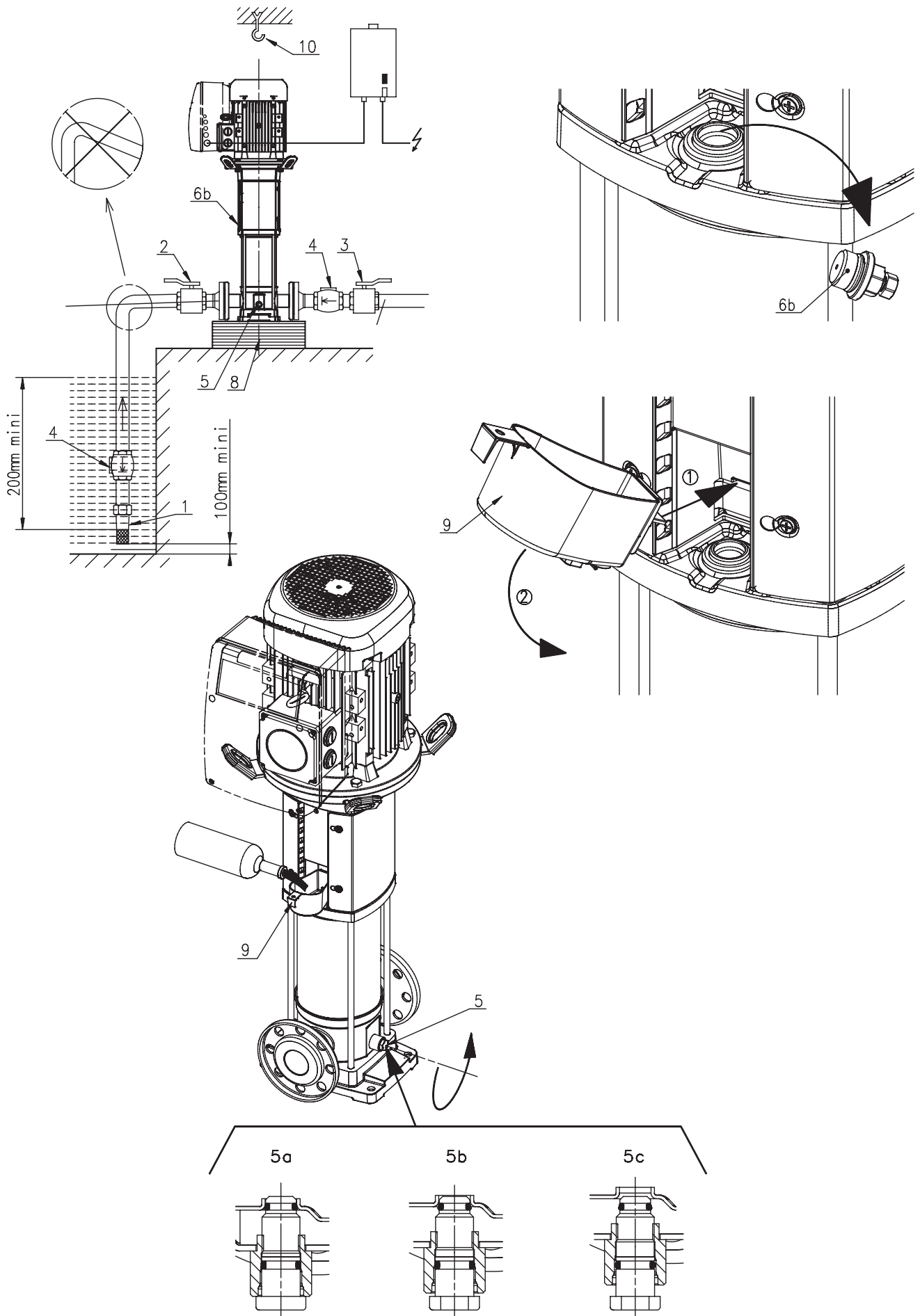

Fig. 3

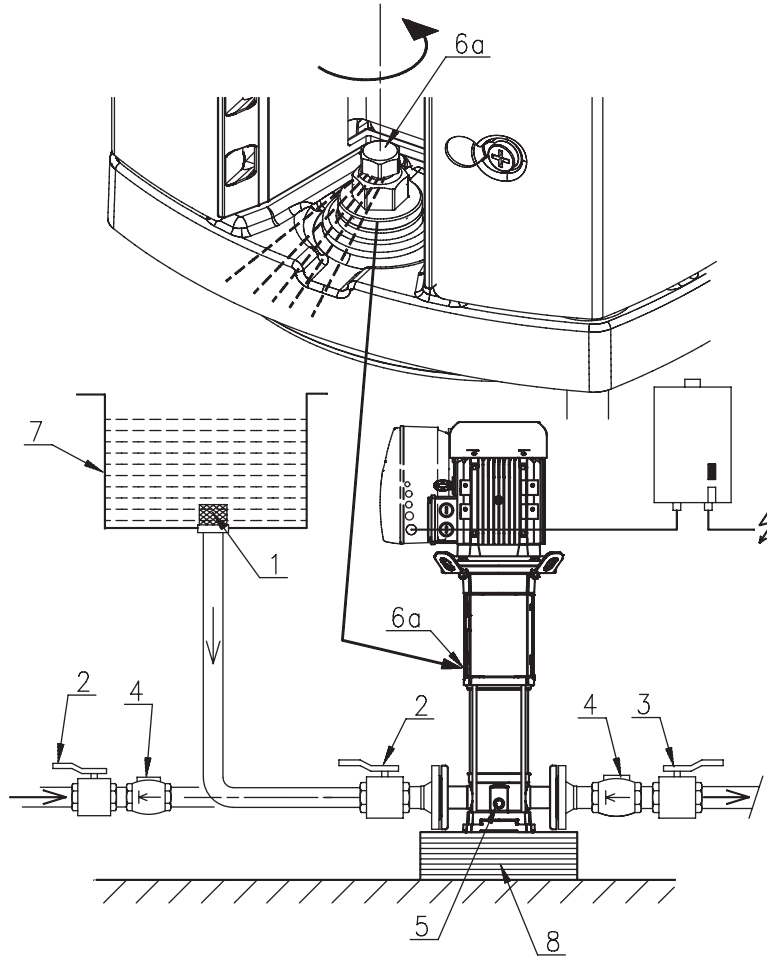
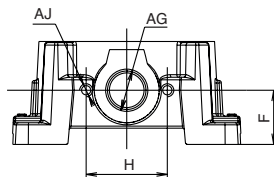
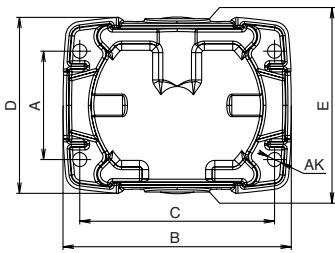
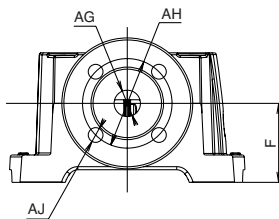
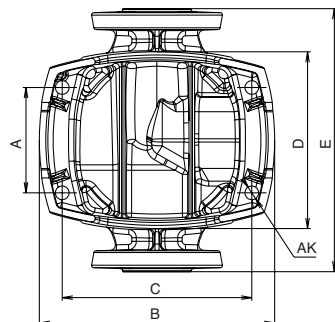

Fig. 4



Type	(mm)										
	A	B	C	D	E	F	G	H	J	K	
Helix V(F), 2.0-VE 2...	PN16	100	212	180	162	160	50	D32	75	2xM10	4xØ13
Helix V(F), 2.0-VE 4...	PN16	100	212	180	162	160	50	D32	75	2xM10	4xØ13
Helix V(F), 2.0-VE 6...	PN16	100	212	180	162	160	50	D32	75	2xM10	4xØ13
Helix V(F), 2.0-VE 10...	PN16	130	251	215	181	200	80	D50	100	2xM12	4xØ13
Helix V(F), 2.0-VE 16...	PN16	130	251	215	181	200	90	D50	100	2xM12	4xØ13



Type	(mm)										
	A	B	C	D	E	F	G	H	J	K	
Helix V(F), 2.0-VE 2...	PN25/PN30	100	212	180	172	250	75	D25	85	4xM12	4xØ13
Helix V(F), 2.0-VE 4...	PN25/PN30	100	212	180	172	250	75	D25	85	4xM12	4xØ13
Helix V(F), 2.0-VE 6...	PN25/PN30	100	212	180	172	250	75	D32	100	4xM16	4xØ13
Helix V(F), 2.0-VE 10...	PN25/PN30	130	252	215	187	280	80	D40	110	4xM16	4xØ13
Helix V(F), 2.0-VE 16...	PN25/PN30	130	252	215	187	300	90	D50	125	4xM16	4xØ13

Fig. 5

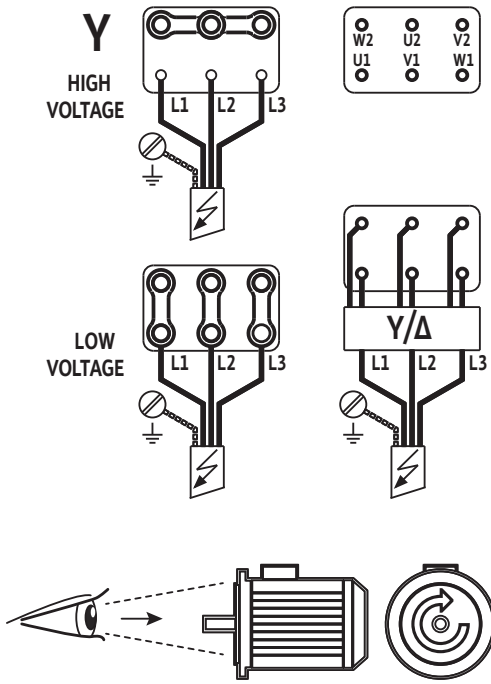

Fig. 6

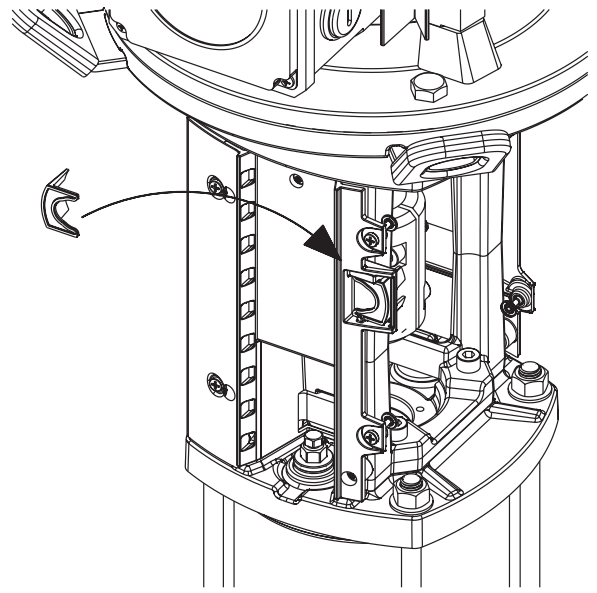
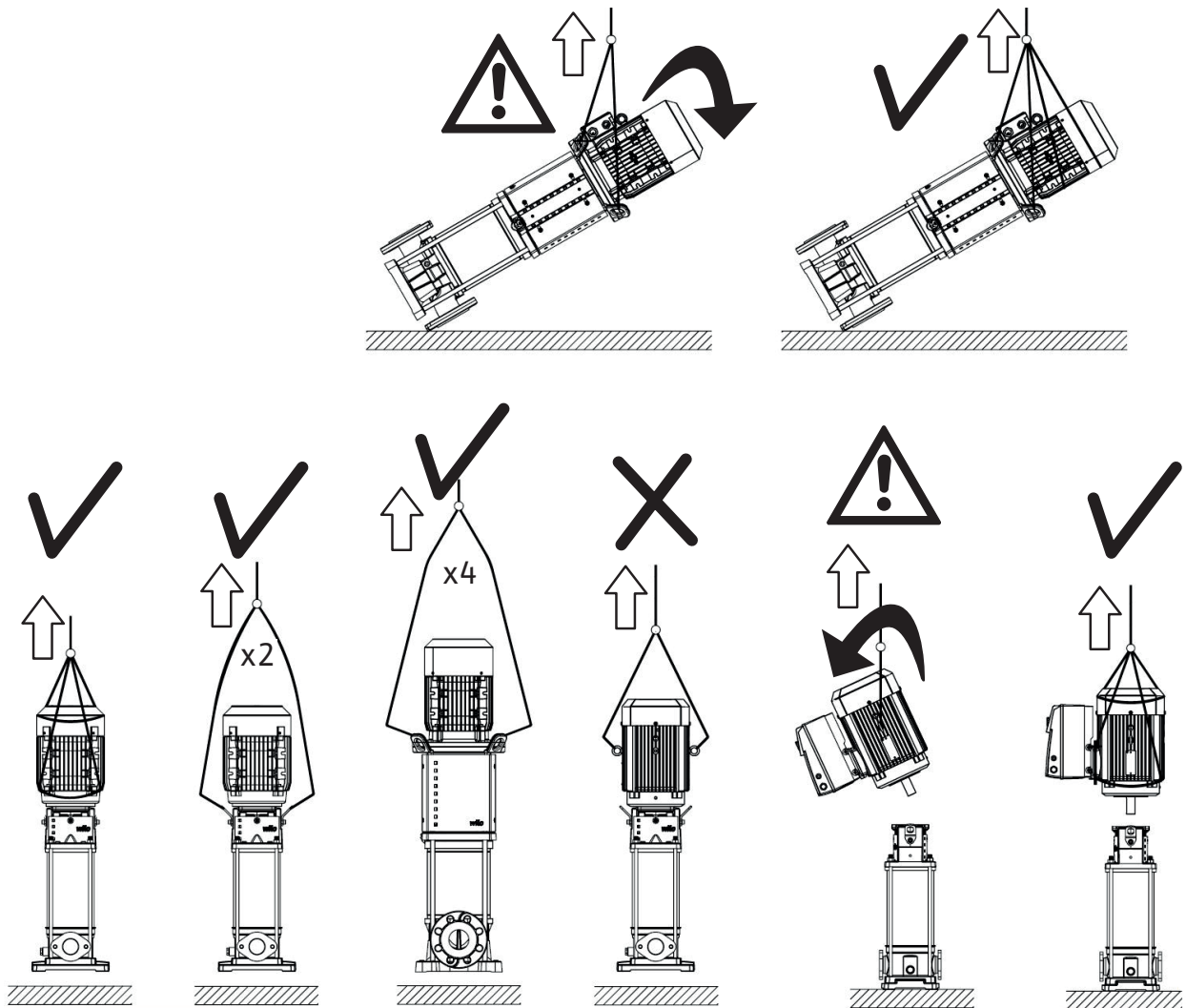

Fig. 7



Sommaire

1	General	9
1.1	About this document	9
2	Safety	9
2.1	Symbols and signal words in the operating instructions	9
2.2	Personnel qualification.....	10
2.3	Danger in the event of non-observance of the safety instructions.....	10
2.4	Safety consciousness on the job	10
2.5	Safety instructions for the user	10
2.6	Safety instructions for installation and maintenance work.....	10
2.7	Unauthorised modification and manufacture of spare parts	11
2.8	Improper use	11
3	Transport and interim storage	11
4	Application	11
4.1	Applications areas.....	11
5	Technical data	12
5.1	Type key.....	12
5.2	Data table.....	12
5.3	Scope of delivery.....	13
5.4	Accessories	13
6	Description and function	13
6.1	Product description	14
6.2	Design of product	14
7	Installation and electrical connection	14
7.1	Commissioning.....	14
7.2	Installation	15
7.3	Pipe connection	16
7.4	Motor connection for bare-shaft pump (without motor).....	16
7.5	Electrical connection	17
7.6	Operation with frequency converter.....	17
8	Commissioning	17
8.1	System filling – Venting	17
8.2	Starting up	18
9	Maintenance	19
10	Faults, causes and remedies	20
11	Spare parts	20
12	Disposal	20

1 General

1.1 About this document

The language of the original operating instructions is English. All other languages of these instructions are translations of the original operating instructions.

These installation and operating instructions are an integral part of the product. They must be kept readily available at the place where the product is installed. Strict adherence to these instructions is a precondition for the proper use and correct operation of the product.

These installation and operating instructions correspond to the relevant version of the product and the underlying safety standards valid at the time of going to print.

2 Safety

These operating instructions contain basic information which must be adhered to during installation, operation and maintenance. For this reason, these operating instructions must, without fail, be read by the service technician and the responsible specialist/operator before installation and commissioning.

It is not only the general safety instructions listed under the main point "safety" that must be adhered to but also the special safety instructions with danger symbols included under the following main points.

- Injuries due to electrical, mechanical and bacteriological factors and electromagnetic fields.
- Damage to the environment due to leakage of hazardous materials.
- Damage to the installation.
- Failure of important product functions.

2.1 Symbols and signal words in the operating instructions

Symbols:



WARNING

General safety symbol



WARNING

Electrical risks



NOTICE

Notes

Signal words

DANGER

Imminent danger.

May result in death or severe injuries if the hazard is not prevented.

WARNING

Non-observance may result in (very) severe injury.

CAUTION

The product risks becoming damaged. "Caution" is used when there is a risk to the product if the user does not observe procedures.

NOTICE

Note containing useful information for the user about the product. It assists the user in the case of an issue;

2.2 Personnel qualification

The installation, operating and maintenance personnel must have the appropriate qualifications for this work. Area of responsibility, terms of reference and monitoring of the personnel are to be ensured by the operator. If the personnel are not in possession of the necessary knowledge, they are to be trained and instructed. This can be accomplished if necessary by the manufacturer of the product at the request of the operator.

2.3 Danger in the event of non-observance of the safety instructions

Non-observance of the safety instructions can result in risk of injury to persons and damage to the environment and the product/unit. Nonobservance of the safety instructions results in the loss for any claims to damages. In particular, non-observance can, for example, result in the following risks:

- Danger to persons due to electrical, mechanical and bacteriological factors
- Damage to the environment due to leakage of hazardous materials
- Property damage
- Failure of important product/unit functions
- Failure of required maintenance and repair procedures

2.4 Safety consciousness on the job

The safety instructions included in these installation and operating instructions, the existing national regulations for accident prevention together with any internal working, operating and safety regulations of the operator are to be complied with.

2.5 Safety instructions for the user

This appliance is not intended for use by persons (including children) with reduced physical, sensory or mental capabilities, or lack of experience and knowledge, unless they have been given supervision or instruction concerning use of the appliance by a person responsible for their safety. Children should be supervised to ensure that they do not play with the appliance.

- If hot or cold components on the product/unit lead to hazards, local measures must be taken to guard them against touching.
- Guards which protect personnel from coming into contact with moving components (e.g. the coupling) must not be removed while the product is in operation.
- Leakages (e.g. from the shaft seals) of hazardous fluids (which are explosive, toxic or hot) must be led away so that no danger to persons or to the environment arises. National statutory provisions are to be complied with.
- Highly flammable materials are always to be kept at a safe distance from the product.
- Danger from electrical current must be eliminated. Local directives or general directives [e.g. IEC, VDE etc.] and local power supply companies must be adhered to.

2.6 Safety instructions for installation and maintenance work

The operator must ensure that all installation and maintenance work is carried out by authorised and qualified personnel, who are sufficiently informed from their own detailed study of the operating instructions

Work on the product/unit must only be carried out when at a standstill. It is mandatory that the procedure described in the installation and operating instructions for shutting down the product/unit be complied with.

Immediately on conclusion of the work, all safety and protective devices must be put back in position and/or recommissioned.

2.7 Unauthorised modification and manufacture of spare parts

Unauthorised modification and manufacture of spare parts will impair the safety of the product/personnel and will make void the manufacturer's declarations regarding safety. Modifications to the product are only permissible after consultation with the manufacturer. Original spare parts and accessories authorised by the manufacturer ensure safety. The use of other parts will absolve us of liability for consequential events.

2.8 Improper use

The operating safety of the supplied product is only guaranteed for conventional use in accordance with Section 4 of the operating instructions. The limit values must on no account fall under or exceed those values specified in the catalogue/data sheet.

3 Transport and interim storage

When receiving the material, check that there has been no damage during the transport. If shipping damage has occurred, take all necessary steps with the carrier within the allowed time.



CAUTION

Outside influences may cause damages. If the delivered material is to be installed later on, store it in a dry place and protect it from impacts and any outside influences (humidity, frost etc.).

The product should be cleaned thoroughly before it is put into temporary storage. The product can be stored for at least one year.

Handle the pump carefully so as not to damage the unit prior to installation.

4 Application

This pump's basic function is to pump hot or cold water, water with glycol or other low viscosity fluids that contain no mineral oil, solid or abrasive substances, or materials having long fibres. The manufacturer's approval is required for use to pump corrosive chemicals.



WARNING

Risk of explosion

Do not use this pump to handle flammable or explosive liquids.

4.1 Applications areas

- water distribution and pressure boosting
- industrial circulation systems
- process fluids
- cooling-water circuits
- firefighting and washing stations
- irrigation systems, etc.

5 Technical data

5.1 Type key

Example: Helix V1605 or Helix2.0-VE1602-1/16/E/KS/400-50xxxx

Helix V(F)	Vertical high-pressure multistage centrifugal pump in in-line design
Helix FIRST V(F)	(F) = VdS certified pump version
Helix2.0-VE	With frequency converter
16	Nominal volume flow in m ³ /h
05	Number of impellers
1	Pump material code 1 = Pump housing stainless steel 1.4301 (AISI 304) + hydraulics 1.4307 (AISI 304) 2 = Pump housing stainless steel 1.4404 (AISI 316L) + hydraulics 1.4404 (AISI 316L) 5 = Pump housing cast Iron EN-GJL-250 (standard coating) + hydraulics 1.4307 (AISI 304)
16	Pipe connection 16 = oval flanges PN16 25 = round flanges PN25 30 = round flanges PN40
E	Seal type code E = EPDM V = FKM
KS	K = Cartridge seal, versions without "K" are equipped with simple mechanical seal S = Lantern orientation align with suction pipe X = X-Care version
1	1 = Single-phase motor - None or 3 = Triphase motor
(With motor)	Motor electrical voltage (V)
400 - 460	50 - 60 = Motor frequency (Hz)
(Without motor)	-38FF265 = Ø motor shaft - lantern size
Bare-shaft pump	
XXXX	Option code (if any)

5.2 Data table

Maximum operating pressure	
Pump casing	16, 25 or 30 bars depend on the model
Maximum suction pressure	10 bars Note : real inlet pressure (Pinlet)+ pressure at 0 flow delivered by the pump must be below the maximum operating pressure of the pump. In case of exceeding maximum operating pressure, the ball bearing and the mechanical seal could be damaged or lifetime could decrease. P Inlet + P at 0 flow ≤ Pmax pump See pump rating plate to know the maximum operating pressure: Pmax
Temperature range	
Liquid temperatures	-30°C to +120°C -15°C to +90°C (with FKM seal) -20°C to + 120°C (with cast iron casing)
Ambient temperature	-15° to +40°C (other temperature on request)
Electrical data	
Motor efficiency	Motor according to IEC 60034-30
Motor Protection index	IP55
Insulation class	155 (F)

Frequency	See pump rating plate
Electrical voltage	
Capacitor value (µF) in single-phase version	
Other data	
Humidity	< 90% without condensation
Altitude	< 1000 m (> 1000m on request)
Maximum suction head	According to pump's NPSH

Sound pressure level dB(A) 0/+3 dB(A)

	Power (kW)																
	0.37	0.55	0.75	1.1	1.5	2.2	3	4	5.5	7.5	11	15	18.5	22	30	37	45
50H z	56	57	57	58	58	62	64	68	69	69	71	71	74	74	76	76	76
60H z	60	61	61	63	63	67	71	72	74	74	78	78	81	81	84	84	84

5.3 Scope of delivery

Complete unit

- Multistage pump
- Installation and operating instructions
- Counter flanges with the corresponding screws, nuts and gaskets for PN16 configuration with oval flanges
- Installation and operating instructions for drive

5.4 Accessories

Original accessories are available for HELIX range:

Designation		Article n°
2x oval counterflanges, stainless steel 1.4301 (screwing)	PN16 – 1"	4016168
2x round counterflanges in stainless steel 1.4404 (screwing)	PN40 – DN25	4016165
2x round counterflanges in steel (welding)	PN40 – DN25	4016162
2x oval counterflanges in stainless steel 1.4301 (screwing)	PN16 – 1" 1/4	4016169
2x round counterflanges in stainless steel 1.4404 (screwing)	PN40 – DN32	4016166
2x round counterflanges in steel (welding)	PN40 – DN32	4016163
2x oval counterflanges in stainless steel 1.4301 (screwing)	PN16 – 1" 1/2	4016170
2x round counterflanges in stainless steel 1.4404 (screwing)	PN40 – DN40	4016167
2x round counterflanges in steel (welding)	PN40 – DN40	4016164
2x oval counterflanges in stainless steel 1.4301 (screwing)	PN16 – 2"	4055063
2x round counterflanges in stainless steel 1.4404 (screwing)	PN40 – DN50	4038589
2x round counterflanges in steel (welding)	PN40 – DN50	4038588
Bypass kit 25 bar		4146786
Bypass kit (with pressure gauge 25 bar)		4146788
Baseplate with dampers for pumps up to 5.5 kW		4157154

The use of new accessories is recommended.

Please contact your Wilo sales office for full accessories list.

6 Description and function

6.1 Product description

Fig. 1

1. Motor connection bolt
2. Coupling gird
3. Mechanical seal
4. Hydraulic stage casing
5. Impeller
6. Pump shaft
7. Motor
8. Coupling
9. Lantern
10. Liner
11. Flange
12. Pump housing
13. Base plate

Fig. 2, 3

1. Strainer
2. Pump suction valve
3. Pump discharge valve
4. Check valve
5. Drain + priming plug
6. Air bleed screw + Filling plug
7. Tank
8. Foundation block
9. Grease
10. Lifting hook

6.2 Design of product

- The Helix pumps are vertical high pressure non self-priming pumps with in-line connection based on multistage design.
- The Helix pumps combine use of both high efficiency hydraulics and motors.
- All metallic parts in contact with water are made of stainless steel.
- For models equipped with heaviest motor (>40 kgs), a specific coupling allows to change the seal without removing the motor. A cartridge seal is then used in order to ease maintenance.
- Special handling devices are integrated in order to facilitate pump installation (Fig. 7).

7 Installation and electrical connection

Installation and electrical work in compliance with any local codes and by qualified personnel only.



WARNING
Bodily injury!

Existing regulations for the prevention of accidents must be observed.



WARNING
Electrical shock hazard

Dangers caused by electrical energy must be excluded.

7.1 Commissioning

Unpack the pump and dispose of the packaging in an environmentally-responsible manner.

7.2 Installation

The pump must be installed in a dry, well-ventilated and frost-free place.



CAUTION

Possible damage of the pump!

Dirt and solder drops in to the pump body can effect the pump operation.

- It is recommended that any welding and soldering work be done before installing the pump.
- Thoroughly flush the system out before installing the pump.

- The pump must be installed in an easily accessible position to facilitate inspection or replacement.
- For heavy pumps, install a lifting hook (Fig. 2, item 10) above the pump in order to ease its disassembly.



WARNING

Risk of accident by hot surfaces!

The pump must be positioned so that someone cannot come into contact with the hot pump surfaces while operation.

- Install the pump in a dry place protected from frost, on a flat concrete block using appropriate accessories. If possible, use an insulating material under the concrete block (cork or reinforced rubber) to avoid any noise and vibration transmission into the installation.



WARNING

Risk of fall!

The pump must be correctly screwed to the ground.

- Place the pump where it will be easy to reach, to facilitate inspection and removal work. The pump must always be installed perfectly upright on a sufficiently heavy concrete base.



WARNING

Risk of parts inside the pump!

Take care to remove closure members of the pump housing before installation.



NOTICE

Each pumps could be tested regarding hydraulic features in factory, some water may remain in them. It is recommended for hygienic purposes, to carry out a rinsing of the pump before any using with potable water supply.

- The installation and connection dimensions are given Fig. 4.
- Lift the pump carefully by using the integrated hooks rings, if necessary with a hoist and suitable slings according to the current hoist guidelines.

WARNING

Risk of fall!

Take care to pump fixations especially for the highest pumps whose centre of gravity may lead to risk during pump handling.

WARNING

Risk of fall!

Use integrated rings only if they are not damaged (no corrosion ...). Replace them if needed.

WARNING**Risk of fall!**

The pump must be never carried by using motor hooks: these are only designed to lift the motor alone.

7.3 Pipe connection

- Connect the pump to the pipes by using appropriate counterflanges, bolts, nuts and gaskets.

**CAUTION**

Tightening of screws or bolts must not exceed.

Configuration PN16 / PN25

M10 – 20 N.m – M12 – 30 N.m

Configuration PN40

M12 – 50 N.m – M16 – 80 N.m

Use of impact wrench is prohibited.

- The circulation sense of the fluid is indicated on the identification label of the pump.
- Pump must be installed in such a way that it is not stressed by the pipework. The pipes must be attached so that the pump does not bear their weight.
- It is recommended that isolation valves be installed on the suction and discharge side of the pump.
- Use of expansion joints may mitigate noise and vibration of the pump.
- As regards the nominal cross-section of the suction pipe, we recommend a cross-section at least as large as that of the pump connection.
- A check valve could be placed on the discharge pipe in order to protect the pump against hammer shock.
- For direct connection to a public drinking water system, the suction pipe must also have a check valve and a guard valve.
- For indirect connection via a tank, the suction pipe must have a strainer to keep any impurities out of the pump and a check valve.

7.4 Motor connection for bare-shaft pump (without motor)

- Remove coupling guards.

**NOTICE**

Coupling guards can be removed without entirely unscrewing screws.

- Install the motor on the pump by using screws (FT lantern size – see product designation) or bolts, nuts and handling devices (FF lantern size – see product designation) provided with the pump : check motor power and dimension in Wilo catalogue.

**NOTICE**

Depending on fluid characteristics, motor power could be modified. Contact The Wilo Customer Services if necessary.

- Close the coupling guards by screwing all screws provided with the pump.

7.5 Electrical connection



WARNING

Electrical shock hazard!

Dangers caused by electrical energy must be excluded.

- Electrical work by a qualified electrician only!
- All electrical connections must be performed after the electrical supply has been switched off and secured against unauthorized switching.
- For safe installation and operation a proper grounding of the pump to the power supply's grounding terminals is required.

- Check that operating current, voltage and frequency used comply with motor plating data.
- The pump must be connected to the power supply by a solid cable equipped with a grounded plug-connection or a main power switch.
- Three-phase motors must be connected to an approved motor starter. The set nominal current must correspond to the electrical data on the pump motor name plate.
- Single-phase motors have integrated thermal protection, which ensures that the pump shuts down if the allowable winding temperature is exceeded and restarts automatically once it is cooled.
- The supply cable must be laid so that it never touches the pipework and/or the pump and motor casing.
- The pump/installation should be grounded in compliance with local regulations. A ground fault interrupter can be used as extra protection.
- The mains connection must be in accordance with the connection plan (Fig. 5 for three-phase motor), (for single-phase motor see connection plan in the motor terminal box).
- Three-phase motors should be protected by a circuit-breaker for the IE class of the motors. Current setting should be adapted to the pump usage, without exceeding the value I_{max} written on the motor nameplate.

7.6 Operation with frequency converter

- Motors used can be connected to a frequency converter in order to adapt pump performance to duty point.
- The converter must not generate voltage peaks at motor terminals higher than 850V and dU/dt slope higher than 2500 V/ μ s.
- In case of higher value, an appropriate filter must be used: contact converter manufacturer for this filter definition and selection.
- Strictly follow instructions provided by the converter manufacturer data sheet for installation.
- Minimum variable speed should not be set below 40% of pump nominal speed.

8 Commissioning

Unpack the pump and dispose of the packaging in an environmentally-responsible manner.

8.1 System filling - Venting



CAUTION

Possible damage of the pump!

Never operate the pump dry.
The system must be filled before starting the pump.

Air evacuation process – Pump with sufficient supply pressure (Fig. 3)

- Close the two guard valves (2, 3).
- Unscrew the venting screw from filling plug (6a).
- Slowly open the guard valve on the suction side (2).
- Retighten the venting screw when air escapes at the venting screw and the pumped liquid flows (6a).

**WARNING****Risk of scalding!**

When the pumped liquid is hot and the pressure high, the stream escaping at the venting screw may cause burns or other injuries.

- Open the guard valve on the suction side completely (2).
- Start the pump and check if direction of rotation matches the one printed on pump plating. If this is not the case, interchange two phases in the terminal box.

**CAUTION****Possible damage of the pump**

A wrong direction of rotation will cause bad pump performances and possibly coupling damage.

- Open the guard valve on the discharge side (3).

Air evacuation process – Pump in suction (Fig. 2)

- Close the guard valve on the discharge side (3).
Open the guard valve on the suction side (2).
- Remove the filling plug (6b).
- Open the drain-priming plug not completely (5b).
- Fill the pump and the suction pipe with water.
- Make sure that there is no air in the pump and in the suction pipe : refilling until complete removal of air is required.
- Close the filling plug with air bleed screw (6b).
- Start the pump and check if direction of rotation matches the one printed on pump plating. If this is not the case, interchange two phases in the terminal box.

**CAUTION****Possible damage of the pump**

A wrong direction of rotation will cause bad pump performances and possibly coupling damage.

- Open the guard valve on the discharge side a little (3).
- Unscrew the air bleed screw from filling plug for air venting (6a).
- Retighten the air-bleed screw when air escapes at the air bleed screw and the pumped liquid flows.

**WARNING****Risk of scalding**

When the pumped liquid is hot and the pressure high, the stream escaping at the air bleed screw may cause burns or other injuries.

- Open the guard valve on the discharge side completely (3).
- Close the drain-priming plug (5a).

8.2 Starting up**CAUTION****Possible damage of the pump**

The pump must not operate at zero flow (closed discharge valve).

**WARNING****Risk of injury!**

When the pump runs, coupling guards must be in place, tightened with all appropriate screws.



WARNING
important noise

Noise emitted by most powerful pumps could be very high : protection must be used in case of long stay close to the pump.



CAUTION
Possible damage of the pump

Installation must be designed in order that no one could be hurt in case of fluid leakage (mechanical seal failure ...).

9 Maintenance

All servicing should be performed by an authorized service representative!



DANGER
Electrical shock hazard!

Dangers caused by electrical energy must be excluded.
All electrical work must be performed after the electrical supply has been switched off and secured against unauthorized switching.



WARNING
Risk of scalding!

At high water temperatures and system pressure close isolating valves before and after the pump. First, allow pump to cool down.

- These pumps are maintenance free. Nevertheless a regular check is recommended every 15 000 hours.
- In option, mechanical seal could be easily replace on some models thanks to its cartridge seal design. Insert its adjusting wedge in its housing (Fig. 6) once mechanical seal position is set.
- Always keep the pump perfectly clean.
- Pumps which are not being used during periods of frost should be drained to avoid damage: Close the guard valves, open completely the drain-priming plug and the air bleed screw.
- Service life: 10 years depending on the operating conditions and whether all requirements described in the operation manual have been met.

10 Faults, causes and remedies



DANGER

Electrical shock hazard!

Dangers caused by electrical energy must be excluded. All electrical work must be performed after the electrical supply has been switched off and secured against unauthorized switching.



WARNING

Risk of scalding!

At high water temperatures and system pressure close isolating valves before and after the pump. First, allow pump to cool down.

Faults	Cause	Remedies
Pump does not run	No current	Check the fuses, the wiring, and the connectors
	The thermistor tripping device has tripped out, cutting off power	Eliminate any cause of overloading of the motor
Pump runs but delivers too little	Wrong direction of rotation	Check the direction of rotation of the motor and correct it if necessary
	Parts of the pump are obstructed by foreign bodies	Check and clean the pipe
	Air in suction pipe	Make the suction pipe airtight
	Suction pipe too narrow	Install a larger suction pipe
	The valve is not open far enough	Open the valve properly
Pump delivers unevenly	Air in pump	Evacuate the air in the pump; check that the suction pipe is airtight. If required, start the pump 20–30s – open the air bleed screw in order to move air away – close the air bleed screw and repeat it several times until no more air is going out of the pump
Pump vibrates or is noisy	Foreign bodies in pump	Remove the foreign bodies
	Pump not properly attached to ground	Retighten the screws
	Bearing damaged	Call the Wilo Customer Service
Motor overheats, its protection trips out	A phase is open-circuit	Check the fuses, the wiring, and the connectors
	Ambient temperature too high	Provide cooling
Mechanical seal is leaking	Mechanical seal is damaged	Replace the mechanical seal

If the fault cannot be solved, please contact the Wilo customer services.

11 Spare parts

All spare parts should be ordered directly from the Wilo customer service. To prevent errors, always quote the data on the pump's rating plate when making an order. The spare parts catalogue is available at www.wilo.com

12 Disposal

Information on the collection of used electrical and electronic products.

Proper disposal and appropriate recycling of this product prevents damage to the environment and dangers to your personal health.



NOTICE**Disposal as domestic waste is forbidden!**

In the European Union, this symbol can appear on the product, the packaging or the accompanying documentation. It means that the electrical and electronic products in question must not be disposed of along with domestic waste.

To ensure proper handling, recycling and disposal of the used products in question, please note the following points:

- Only hand over these products at designated, certified collecting points.
- Observe the locally applicable regulations! Please consult your local municipality, the nearest waste disposal site, or the dealer who sold the product to you for information on proper disposal. For further information on recycling, go to www.wilo-recycling.com.

Subject to change without prior notice.





wilo



Local contact at
www.wilo.com/contact

Pioneering for You

WILO SE
Wilopark 1
44263 Dortmund
Germany
T +49 (0)231 4102-0
F +49 (0)231 4102-7363
wilo@wilo.com
www.wilo.com